



US010369689B2

(12) **United States Patent**
Ballard

(10) **Patent No.:** **US 10,369,689 B2**

(45) **Date of Patent:** **Aug. 6, 2019**

(54) **ADJUSTABLE UNIVERSAL HARDWARE
INSTALLATION AND MACHINING JIG FOR
CARPENTRY APPLICATION**

USPC 33/419, 425, 427, 428, 452, 464;
269/287, 288
See application file for complete search history.

(71) Applicant: **McKay Ballard**, Pleasant Grove, UT
(US)

(56) **References Cited**

(72) Inventor: **McKay Ballard**, Pleasant Grove, UT
(US)

U.S. PATENT DOCUMENTS

(*) Notice: Subject to any disclaimer, the term of this
patent is extended or adjusted under 35
U.S.C. 154(b) by 221 days.

- 2,872,735 A * 2/1959 Roberts B43L 13/048
33/427
- 4,713,887 A * 12/1987 Kitamura B23 1/621
33/1 M
- 5,311,791 A * 5/1994 Yanagisawa B23 1/621
103/143
- 5,743,684 A * 4/1998 Rex B23B 47/287
408/115 R
- 9,751,206 B1 * 9/2017 Nelson B25H 7/04

(21) Appl. No.: **15/469,339**

(22) Filed: **Mar. 24, 2017**

* cited by examiner

(65) **Prior Publication Data**

US 2018/0272521 A1 Sep. 27, 2018

Primary Examiner — William V Gilbert

(74) *Attorney, Agent, or Firm* — Steven Rinehart

(51) **Int. Cl.**
B25H 7/00 (2006.01)

(52) **U.S. Cl.**
CPC **B25H 7/00** (2013.01)

(58) **Field of Classification Search**
CPC B25H 7/02; B25H 7/04; B25H 1/0092;
B25H 7/00; B25H 7/045; B25H 1/0021;
B25H 1/0078; B25H 1/02; B25H 1/04;
B25H 1/06; E04F 21/003; E04F 21/0007;
E05N 17/06; E05D 11/0009; Y10T
29/4984

(57) **ABSTRACT**

An adjustable universal carpentry jig for manipulating a workpiece, the jig having a rectangular base, the base defining a plurality of guide tracks within which a detachable adjustment arm travels for precise measurement of the workpiece. The adjustment arm comprises a plurality of clamps or clasps for affixing the adjustment arm to the base.

5 Claims, 6 Drawing Sheets

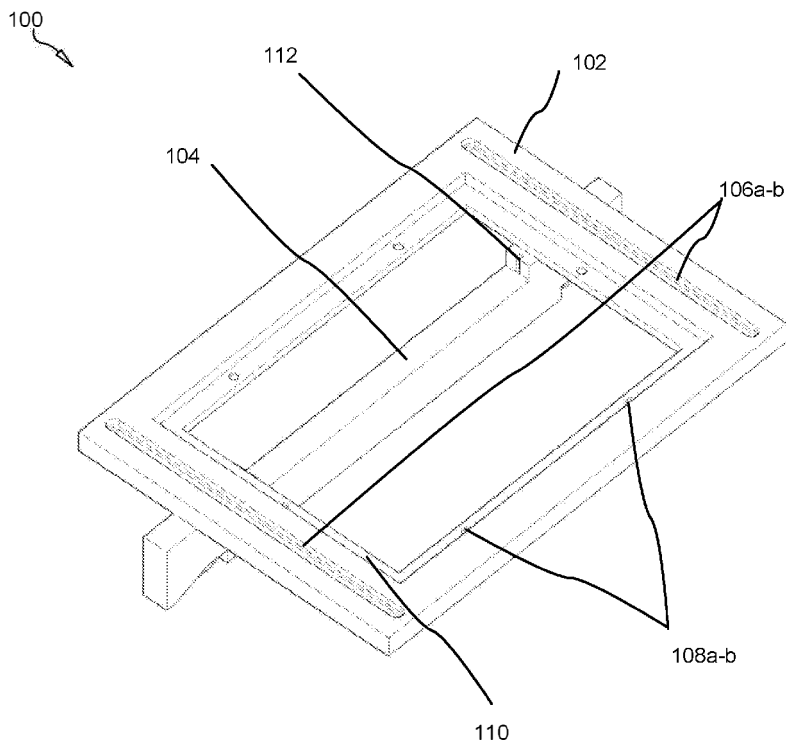

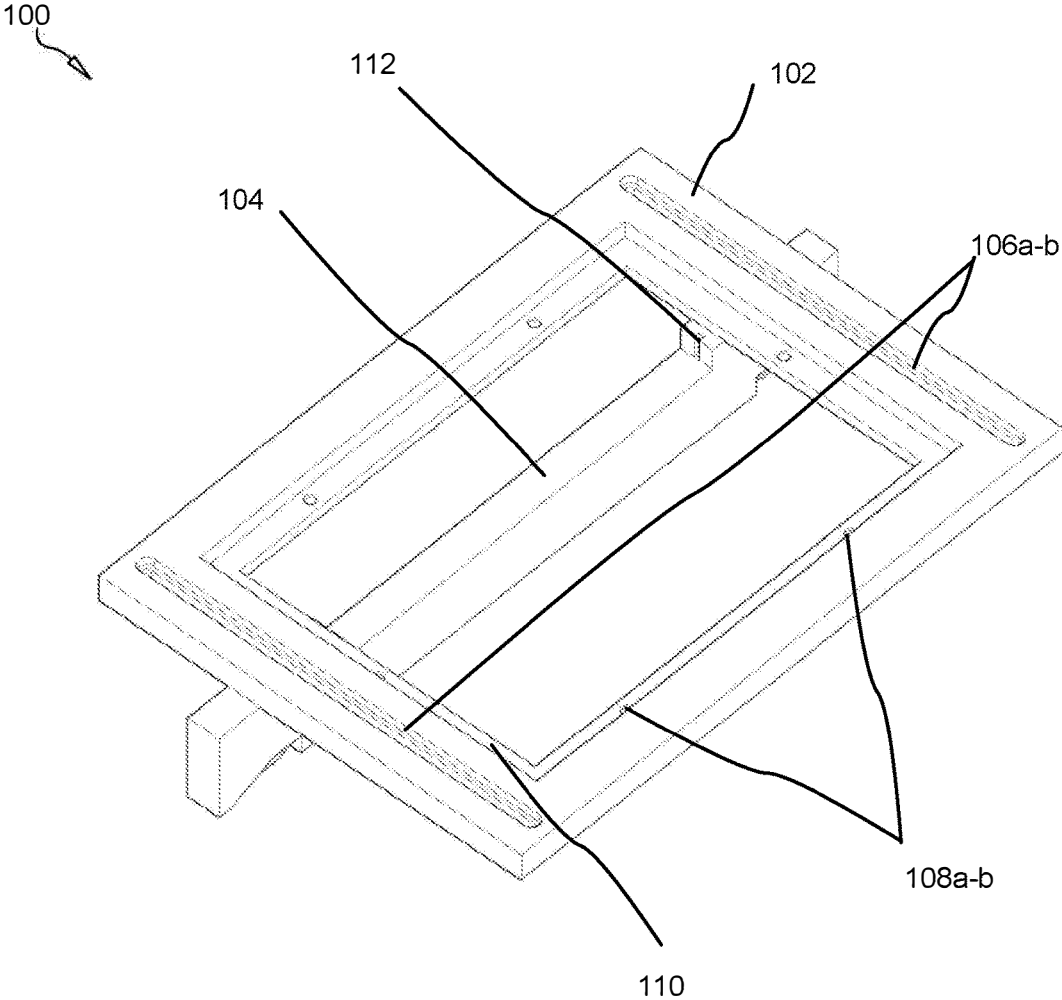

FIG. 1

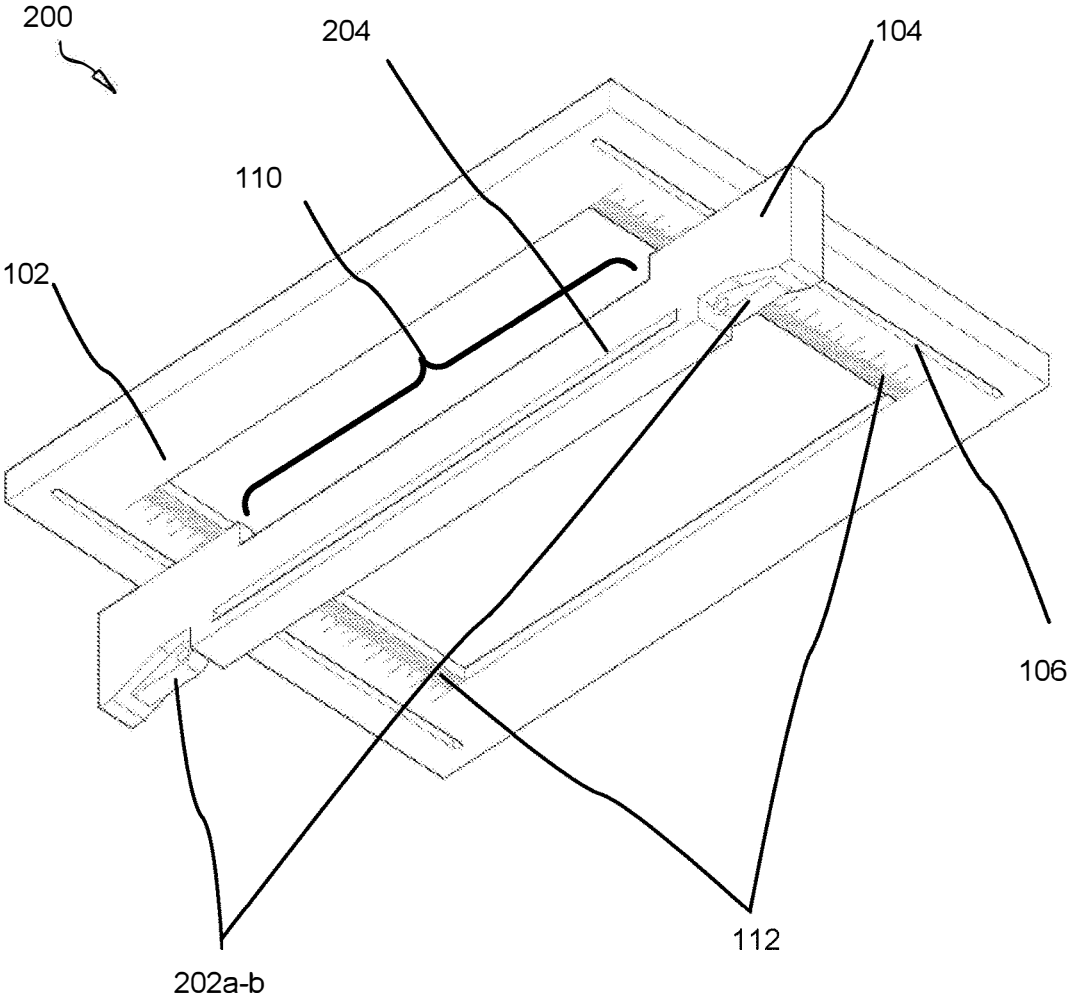

FIG. 2

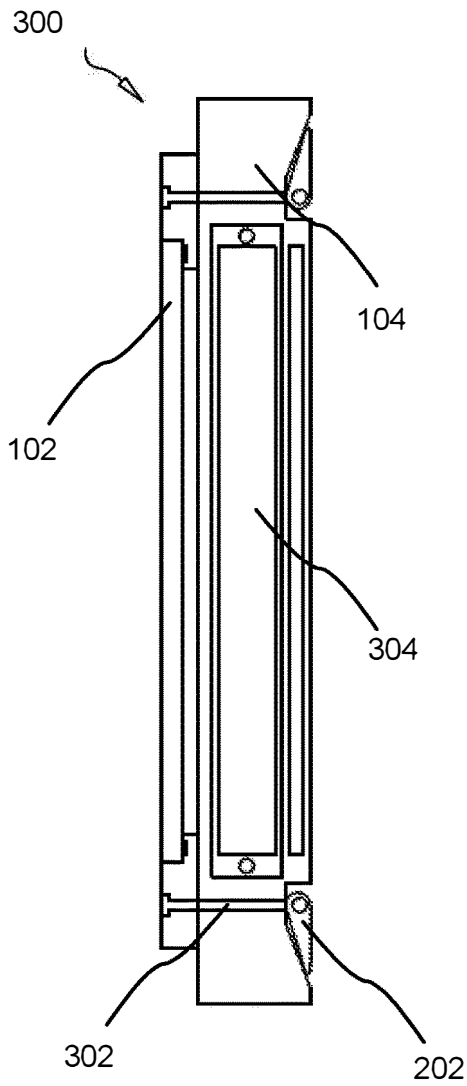

FIG. 3A

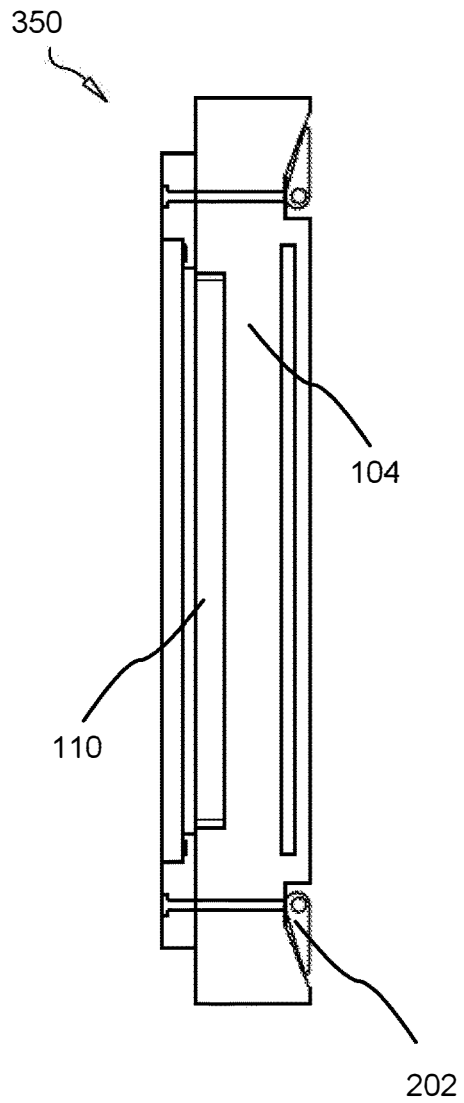

FIG. 3B

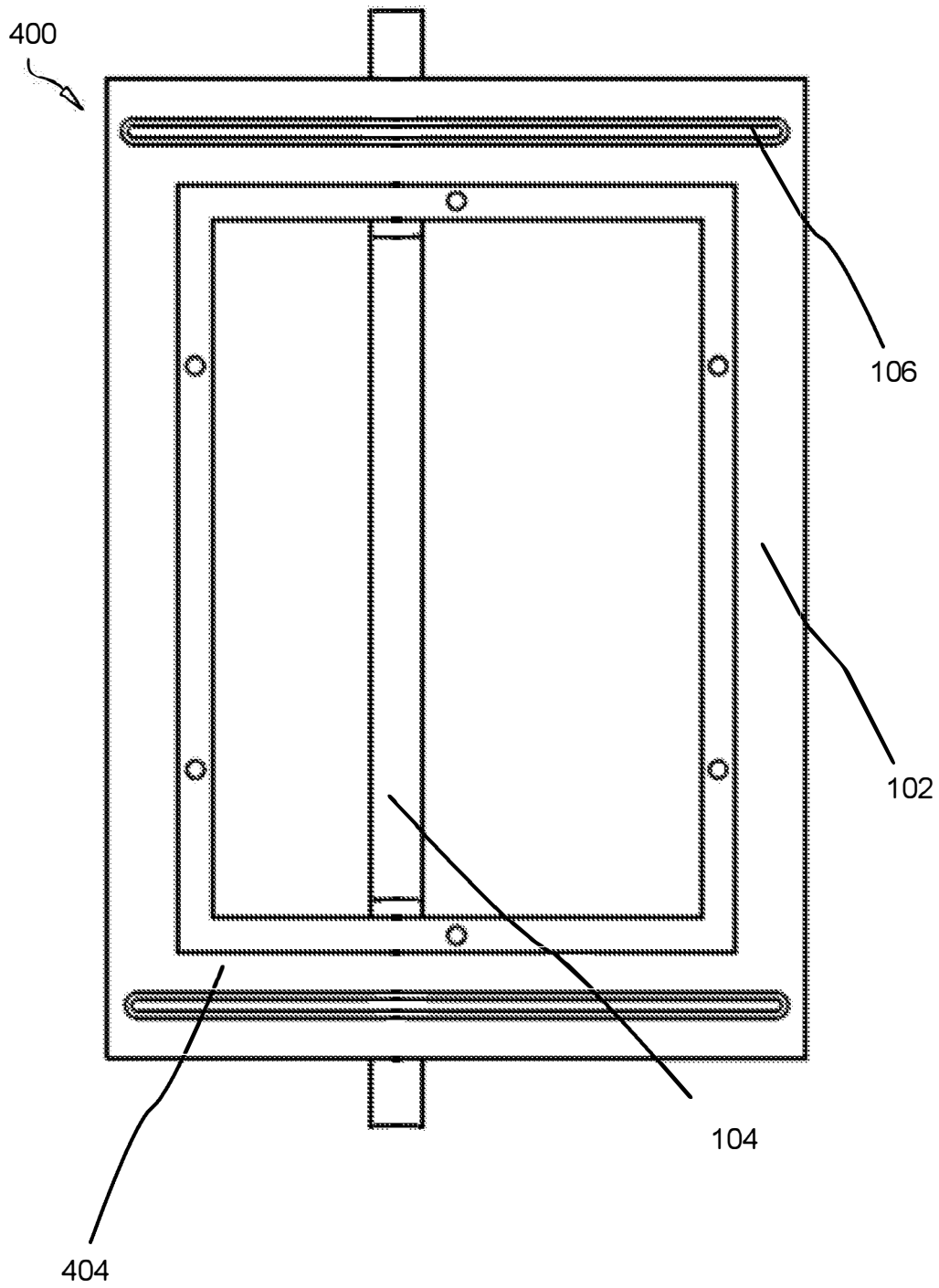

FIG. 4

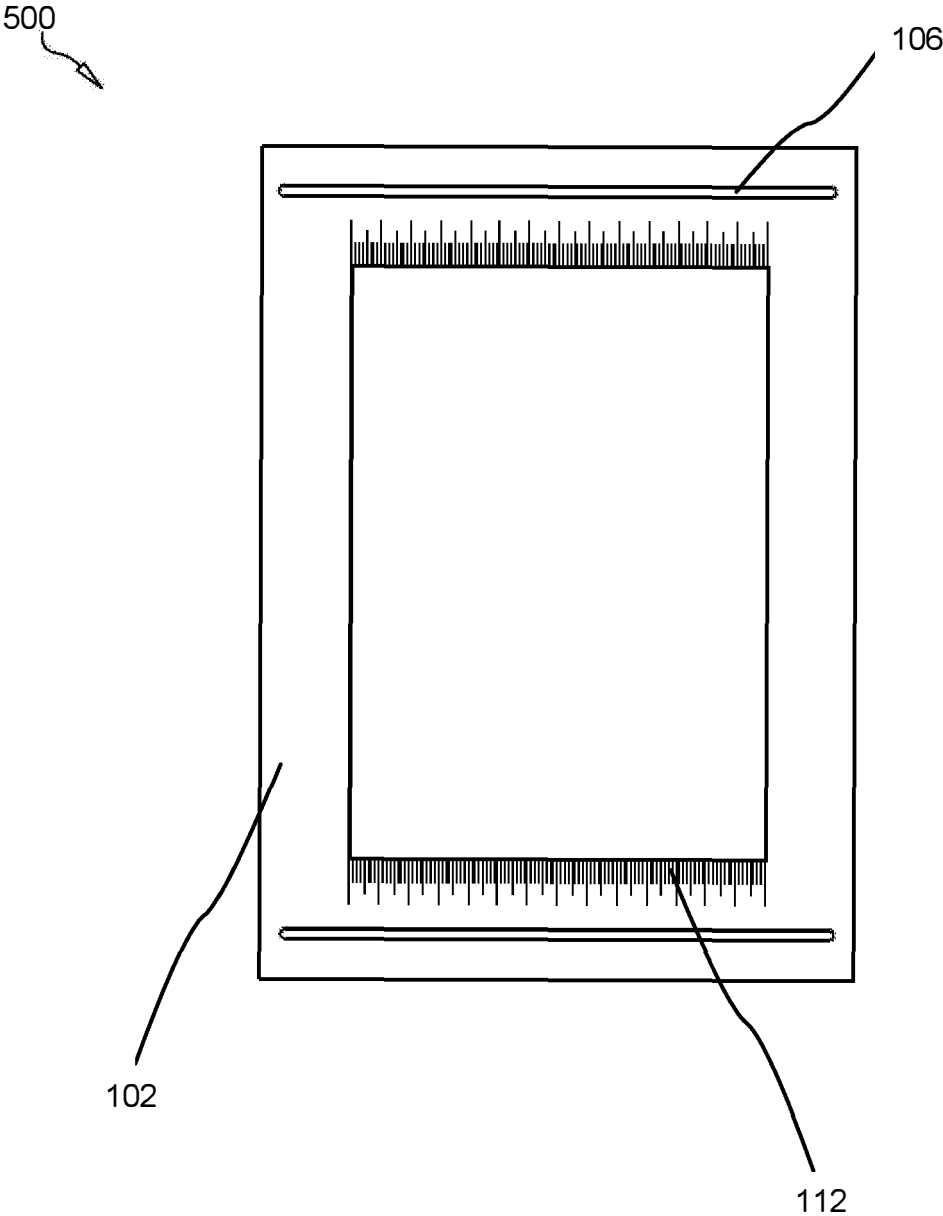

FIG. 5

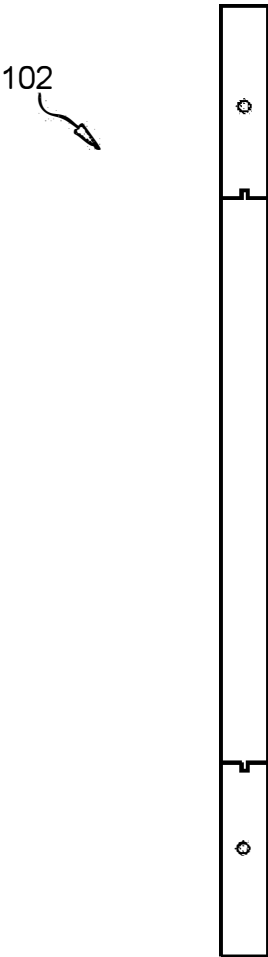

FIG. 6A



FIG. 6B

1

**ADJUSTABLE UNIVERSAL HARDWARE
INSTALLATION AND MACHINING JIG FOR
CARPENTRY APPLICATION**

BACKGROUND OF THE INVENTION

Field of the Invention

This invention relates to carpentry and cabinetmaking and more particularly relates to a jig for wood templates.

Description of the Related Art

Jigs are known throughout the art for assisting carpenters in milling or machining a templet (such as a strike plate cutout), doors, and other workpieces. Carpentry requires precise and expeditious measuring, reliable tools, and mistakes can be costly. Tape measures and other measuring devices such as squares have traditionally been used by carpenters, but are only of limited efficiency in modern carpentry. Many carpentry devices are used not to cut, drill, saw, bevel or carve work pieces, but rather to mark them for subsequent application of cutting tools.

Integration of complicated design into workpieces has become more common as has the time required of carpenters to successfully complete a job. Measuring and marking of workpieces can be burdensome and errors can render a workpiece useless. Retaining a workpiece in a vice for precision measuring operation is impractical for most workpieces. Makeshift arrangements are commonly utilized, none of which provide optimal benefit.

In fine carpentry work, many carpentry operations have to be performed as close to perpendicularity as possible with respect to the surface of a workpiece and the edges of workpieces. In the case of hardware installed on a door or cabinet doors of the kind used in kitchens and bathrooms, for example, small a perpendicularity can cause asymmetry after installation, unhappy customers, unnecessary material costs and lost margins.

While angular templates (or templates) are available for measuring and machining, including applying and marking, including miter lines and cutting lines, there are no universal jigs available. A universal jig is needed which can be utilized to more efficiently facilitate measuring, machining and working of planar wooden surfaces including doors. None are known in the art which accomplish the functions of the disclosed invention herein.

In summary, the lack of adequate solutions to the above-mentioned problems remain unsolved. No apparati or methods which have heretofore been designed cure the inefficiencies in the art. As a result, there is a need for the adjustable carpentry jig provided below.

SUMMARY OF THE INVENTION

From the foregoing discussion, it should be apparent that a need exists for an adjustable carpentry jig. Beneficially, such an apparatus would overcome many of the difficulties and concerns expressed above.

The present invention has been developed in response to the problems and needs in the art that have not yet been fully solved by currently available apparati and methods. Accordingly, the present invention has been developed to provide an adjustable carpentry jig comprising: a rectangular base having a top surface and bottom surface, the top surface of the base defining pair of parallel guide tracks within which an adjustment arm can travel; wherein the base defines a

2

hollow rectangular, interior recess for detachably receiving a workpiece; wherein the base comprises an uninterrupted cantilevered abutment templet circumscribing the interior recess for abutting the workpiece; and a detachable adjustment arm for traveling within two or more guide tracks, the detachable adjustment arm having a planar top surface which abuts one of the top surface and bottom surface of the base, the planar top surface of the adjustment arm defining a recess for spacing the adjustment arm from the workpiece.

In some embodiments, the bottom surface of the adjustable carpentry jig of the base defines a pair of parallel guide tracks within which the adjustment arm can travel. The adjustment arms may travel laterally from one side of the jig to another.

The adjustment arm may comprise a plurality of clasps for affixing the adjustment arm to the base.

The adjustment arm may define a second templet recess for receiving a second templet. The adjustment arm may define one or more bevel offset recesses.

These features and advantages of the present invention will become more fully apparent from the following description and appended claims, or may be learned by the practice of the invention as set forth hereinafter

BRIEF DESCRIPTION OF THE DRAWINGS

In order that the advantages of the invention will be readily understood, a more particular description of the invention briefly described above will be rendered by reference to specific embodiments that are illustrated in the appended drawings. Understanding that these drawings depict only typical embodiments of the invention and are not therefore to be considered to be limiting of its scope, the invention will be described and explained with additional specificity and detail through the use of the accompanying drawings.

FIG. 1 is top-side perspective view of an adjustable carpentry jig in accordance with the present invention;

FIG. 2 is bottom-side perspective view of an adjustable carpentry jig in accordance with the present invention;

FIG. 3A is side perspective view of an alternate embodiment of an adjustment arm of an adjustable carpentry jig in accordance with the present invention;

FIG. 3B is side perspective view of adjustment arm of an adjustable carpentry jig in accordance with the present invention;

FIG. 4 is lower perspective view of an adjustable carpentry jig in accordance with the present invention;

FIG. 5 is lower perspective view of an adjustable carpentry jig with detached adjustment arm in accordance with the present invention;

FIG. 6A is side perspective view of an adjustable carpentry jig with detached adjustment arm in accordance with the present invention; and

FIG. 6B is side perspective view of an adjustable carpentry jig with detached adjustment arm in accordance with the present invention.

DETAILED DESCRIPTION OF THE
INVENTION

Reference throughout this specification to “one embodiment,” “an embodiment,” or similar language means that a particular feature, structure, or characteristic described in connection with the embodiment is included in at least one embodiment of the present invention. Thus, appearances of the phrases “in one embodiment,” “in an embodiment,” and

similar language throughout this specification may, but do not necessarily, all refer to the same embodiment.

Furthermore, the described features, structures, or characteristics of the invention may be combined in any suitable manner in one or more embodiments. In the following description, numerous specific details are provided to provide a thorough understanding of embodiments of the invention. One skilled in the relevant art will recognize, however, that the invention may be practiced without one or more of the specific details, or with other methods, components, materials, and so forth. In other instances, well-known structures, materials, or operations are not shown or described in detail to avoid obscuring aspects of the invention.

It is an object of the present invention to provide a jig, or templet housing unit, with an adjustable guide or arm for centering a templet inserted into the jig.

FIG. 1 is top-side perspective view of an adjustable carpentry jig **100** in accordance with the present invention. The jig **100** comprises a base **102**, an adjustable arm **104** defining a chip board securement groove **112**, guide tracks **106a-b**, linearly-arranged holes **108a-b**, and a templet abutment.

The base **102** comprises a templet housing unit for securing a templet in place on a x and y axis. The base **102** may comprise one or more magnets for securing the inserted templet on a z axis as well.

The base **102** is provided with a templet abutment **110** recessed beneath a top surface of the base **102** in the form of a cantilevered lip circumscribing in rectangular form the interior edge of the base **102**.

The base **102** as shown is fabricated from extruded aluminum, but may be fabricated in other embodiments from wood, steel, or polymeric materials.

The adjustment arm **104** is slidable affixed to the base **102** to travel laterally along a horizontal axis in two guide tracks **106a-b**. The adjustment arm **104** may be detachable and may affix slidably to either the top surface or bottom surface of the base **102**. In the shown embodiments, the adjustment arm is detachably affixed to the bottom surface. The adjustment arm **104** is affixable in position above or below a templet or workpiece received by the base **102**. The templet or workpiece may then be precision milled, machined, contoured, routed, drilled or otherwise manipulated by a carpenter.

FIG. 2 is bottom-side perspective view of an adjustable carpentry jig **200** in accordance with the present invention. The jig **200** comprises a base **102**, an adjustment arm **104** comprising a recess **110**, defining a bevel offset recess **204** and having clasps **202a-b**. The base **102** defines two guide tracks **106** within which the adjustable arm **104** travels. Marking **112** is printed, etched, engraved, adhered or otherwise visibly depicted on the bottom surface of the base **102** for measuring a distance from inside interior edge of the base **102** to the adjustment arm **104**.

The recess **110** functions, inter alia, to allow a bit on a router to engage the workpiece between the adjustment arm **104** and a bottom or top surface of the workpiece. The recess **110** also is adapted to receive a sacrificial blow out board, or chip board, for abutting and bracing an edge of the workpiece and preventing chips or blow out to the edge of the workpiece caused by cutting, machining or drilling operations near the edge of the workpiece. The adjustment arm comprises a chip board securement groove **112** receiving a corresponding protrusion on a chip board (as shown in relation to FIG. 1 above).

FIG. 3A illustrates side perspective views of an alternative embodiment of an adjustment arm **300** of an adjustable carpentry jig in accordance with the present invention. In this alternative embodiment, the adjustment arm **104** defines a second recess, or second templet recess **304**, for receiving a second templet. This second templet may be used for drilling or machining operations to the edge of a door or workpiece received by the base **102**, including lock installation operations.

FIG. 3B illustrates side perspective views of adjustment arm **350** of an adjustable carpentry jig in accordance with the present invention. The jig **300** comprises a base **102** and an adjustment arm **104** having a clasp **202**.

The clasp **202** comprises a bolt **302** which traverses the base **102** on its z axis and travels within the guide track **106**. The clasp **202** may comprise a clamp as known to those of skill in the art.

The bevel offset recess serves to receive a rubber insert, or adjustable rubber insert, adapted to facilitate the angling of a strike edge of a door. The rubber insert tilted the workpiece and allows a carpenter or operator to change the angle of the strike edge.

FIG. 4 is lower perspective view of an adjustable carpentry jig **400** in accordance with the present invention. The base **102** of the jig **400** comprises a top surface **404**.

FIG. 5 is lower perspective view of an adjustable carpentry jig **500** with detached adjustment arm in accordance with the present invention. The jig **500** comprises marking **112** as shown.

FIG. 6A is side perspective view of an adjustable carpentry jig **600** with detached adjustment arm in accordance with the present invention.

The base **102** may comprise four sides affixed together as shown.

FIG. 6B is a side perspective view of an adjustable carpentry jig with detached adjustment arm in accordance with the present invention.

As shown.

The present invention may be embodied in other specific forms without departing from its spirit or essential characteristics. The described embodiments are to be considered in all respects only as illustrative and not restrictive. The scope of the invention is, therefore, indicated by the appended claims rather than by the foregoing description. All changes which come within the meaning and range of equivalency of the claims are to be embraced within their scope.

What is claimed:

1. An adjustable carpentry jig comprising:
 - a rectangular base having a top surface and bottom surface, the top surface of the base defining a pair of parallel guide tracks within which an adjustment arm can travel;
 - wherein the base defines a hollow rectangular, interior recess for detachably receiving a workpiece;
 - wherein the base comprises an uninterrupted cantilevered abutment templet circumscribing the interior recess for abutting the workpiece; and
 - a detachable adjustment arm, the detachable adjustment arm having a planar top surface which abuts one of the top surface and bottom surface of the base, the planar top surface of the adjustment arm defining a recess for spacing the adjustment arm from the workpiece.
2. The adjustable carpentry jig of claim 1, wherein the bottom surface of the base defines a pair of parallel guide tracks within which the adjustment arm can travel.

5

6

3. The adjustable carpentry jig of claim 1, wherein the adjustment arm travels laterally from one side of the jig to another.

4. The adjustable carpentry jig of claim 1, wherein the adjustment arm comprises a plurality of clasps for affixing the adjustment arm to the base.

5. The adjustable carpentry jig of claim 1, wherein the adjustment arm defines a second templet recess for receiving a second templet.

* * * * *

10